

# USE, INSTALLATION AND MAINTENANCE INSTRUCTIONS FOR BUILT-IN HOT PLATES

Dear User,

We are sincerely grateful to you for purchasing one of our products. This appliance has been designed to meet all the modern requirements and is manufactured from the finest materials and components.

We would ask you to read the instructions within this booklet very carefully so as to enable you to obtain quality results from the outset.

The design of the figures contained in this handbook is purely indicative.

**THE APPLIANCE MUST BE INSTALLED ONLY BY A QUALIFIED ELECTRICIAN IN COMPLIANCE WITH THE INSTRUCTIONS PROVIDED. THE MANUFACTURER DECLINES ALL RESPONSIBILITY FOR IMPROPER INSTALLATION WHICH MAY HARM PERSONS AND ANIMALS AND DAMAGE PROPERTY.**

**THE APPLIANCE MUST BE USED FOR THE PURPOSE FOR WHICH IT WAS EXPRESSLY DESIGNED. ANY OTHER USE (e.g. HEATING ROOMS) IS CONSIDERED TO BE IMPROPER AND CONSEQUENTLY DANGEROUS. THE MANUFACTURER DECLINES ALL RESPONSIBILITY FOR DAMAGE RESULTING FROM IMPROPER AND IRRESPONSIBLE USE.**

**Blanco**

**BCG640 & BCG641**

**Series 4 burner inbuilt  
hotplate**

**BLANCO**

■ Performance First

MOD.: BCG641WX

The Manufacturer shall not be held responsible for any inaccuracies in this handbook due to printing or transcription errors, also the designs in the figures are purely indicative.

The Manufacturer also reserves the right to make any modifications to the products as may be considered necessary or useful, also in the interests of the user, without jeopardizing the main functional and safety features on the products themselves.

If your hotplate requires service, please contact your local customer service centre or your nearest Blanco agent listed at the back of this booklet.

COD. 01099GG - 26.02.2002

# DESCRIPTION OF THE HOT PLATES

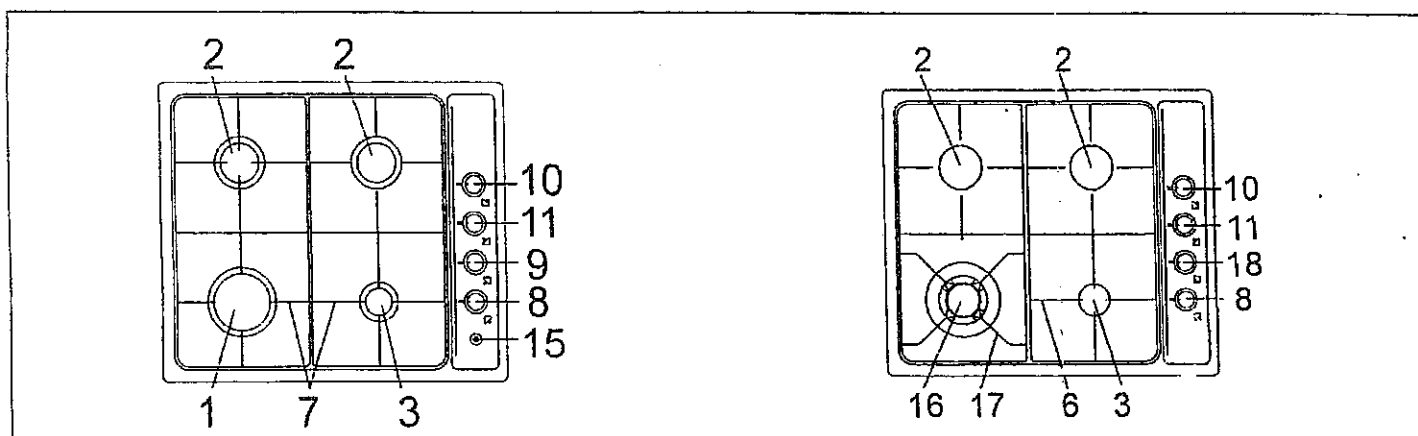

- 1 Rapid gas burner
- 2 Semi-rapid gas burner
- 3 Auxiliary gas burner
- 6 Enamelled steel trivet 1 burner
- 7 Enamelled steel trivet 2 burner
- 8 Burner 3 control knob
- 9 Burner 1 control knob
- 10 Burner 2 control knob (right)
- 11 Burner 2 control knob (left)
- 16 Ultra rapid gas burner/Wok
- 17 Enamelled steel trivet for ultra rapid burner
- 18 Burner 16 control knob

	<i>Natural</i>	<i>Propane</i>
	12.0 MJ	12.0 MJ
	7.3 MJ	6.9 MJ
	4.2 MJ	3.8 MJ
	15.0 MJ	15.0 MJ

*Attention: this appliance has been manufactured for domestic use only and its employment by private person.*

# USE

## 1) BURNERS

A diagram is screen-printed above each knob on the front panel. This diagram indicates to which burner the knob in question corresponds. After having opened the gas mains or gas bottle tap, light the burners as described below:

### - Manual ignition

Push and turn the knob corresponding to the required burner in an anticlockwise direction until it reaches the full on position (large flame fig. 1), then place a lighted match near the burner.

### - Electrical ignition

Push and turn the knob corresponding to the required burner in an anticlockwise direction until it reaches the full on position (large flame fig. 1), then depress and release the ignition button "E".

### - Automatic electrical ignition

Push and turn the knob corresponding to the required burner in an anticlockwise direction until it reaches the full on position (large flame fig. 1), then depress the knob.

### - Lighting burners equipped with flame failure device

The knobs of burners equipped with flame failure device must be turned in an anticlockwise direction until they reach the full on position (large flame fig. 1) and come to a stop. Now depress the knob in question and repeat the previously indicated operations.

Keep the knob depressed for about 10 seconds once the burner has ignited.

### HOW TO USE THE BURNERS

Bear in mind the following indications in order to achieve maximum efficiency with the least possible gas consumption:

- Use adequate pans for each burner (consult the following table and fig. 2).

- When the pan comes to the boil, set the knob to the reduced rate position (small flame fig. 1).
- Always place a lid on the pans.

Burners	Power ratings		Pan Ø in cm
	Natural	Propane	
Ultra rapid or Wok	15.0 MJ	15.0 MJ	22 - 24
Rapid	12.0 MJ	12.0 MJ	20 - 22
Semi-rapid	7.3 MJ	6.9 MJ	16 - 18
Auxiliary	4.2 MJ	3.8 MJ	10 - 14

### WARNINGS:

- *Burners with flame failure device may only be ignited when the relative knob has been set to the Full on position (large flame fig. 1).*
- *Matches can be used to ignite the burners in a blackout.*
- *Never leave the appliance unattended when the burners are being used. Make sure there are no children in the near vicinity. Particularly make sure that the pan handles are correctly positioned and keep a check on foods requiring oil and grease to cook since these products can easily catch fire.*
- *Never use aerosols near the appliance when it is operating.*
- *If the built-in hot plate has a lid, any spilt food should be immediately removed from this before it is opened. If the appliance has a glass lid, this could shatter when the hot plate becomes hot. Always switch off all the burners before closing the lid.*
- *This appliance is not to be installed in marine craft. Where this appliance is installed in a caravan, it shall not be used as a space heater.*
- *Do not store or use flammable liquids or items in the vicinity of the hotplate.*

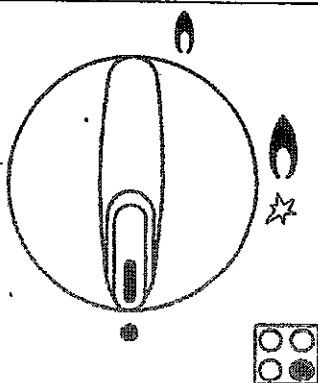

FIG. 1

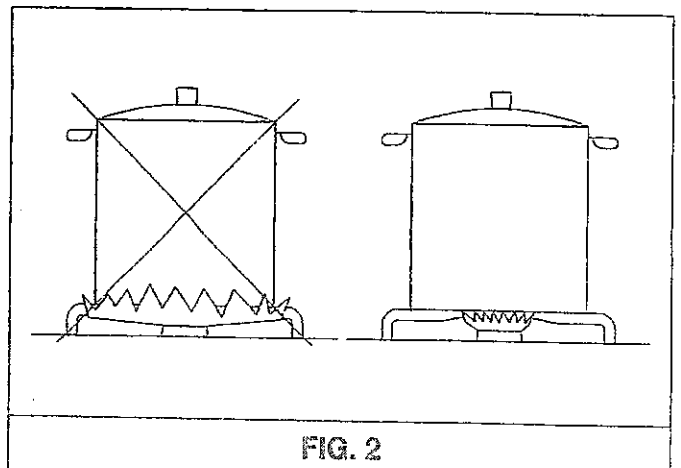

FIG. 2

# USE

## Notes:

Use of a gas cooking appliance produces heat and moisture in the room in which it is installed. The room must therefore be well ventilated by keeping the natural air vents clear (fig. 3) and by activating the mechanical aeration device (suction hood or electric fan fig. 4 and fig. 5). Intensive and lengthy use of the appliance may require additional ventilation. This can be achieved by opening a window or by increasing the power of the mechanical exhausting system if installed.

## Abnormal Operation:

Any of the following are considered to be abnormal operation and may require servicing:

- Yellow tipping of the hob burner flame.
- Sooting up of cooking utensils.
- Burners not igniting properly.
- Burners failing to remain alight.
- Burners extinguished by cupboard doors.
- Gas valves which are difficult to turn.

In case the appliance fails to operate correctly, contact the authorised service provider in your area.

(\*) Air inlet – minimum section 100 cm<sup>2</sup>

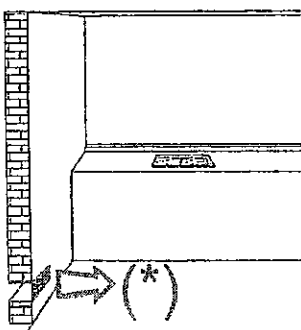

FIG. 3

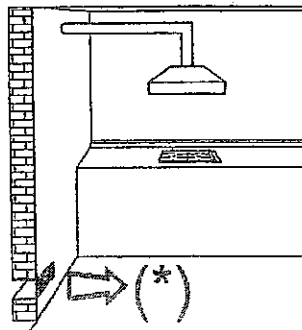

FIG. 4

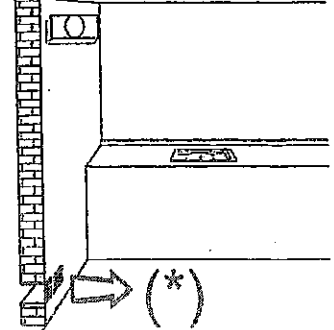

FIG. 5

# CLEANING

## IMPORTANT:

Always disconnect the appliance from the gas and electricity mains before carrying out any cleaning operation.

## 2) HOT PLATE

Periodically wash the hot plate, the enamelled steel pan support, the enamelled burner caps "A", "B" and "C" and the burner heads "T" (see fig. 6 and 7) with lukewarm soapy water. Following this, all parts should be thoroughly rinsed and dried. Never wash them while they are still warm and never use abrasive powders. Do not allow vinegar, coffee, milk, salted water, lemon or tomato juice from remaining in contact with the enamelled surfaces for long periods of time.

## WARNINGS:

Comply with the following instructions, before remounting the parts:

- Check that burner head slots have not become clogged by foreign bodies.
- Check that enamelled burner cap "A", "B" and "C" (fig. 6 and 7) have correctly positioned on the burner head. It must be steady.
- The exact position of the pan support is established by the rounded corners, which should be set towards the side edge of the hot plate.
- Do not force the taps if they are difficult open or close. Contact the technical assistance service for repairs.
- Correctly preserve the plate after use by treating it with special products, easily available on the market. This will keep the surface of the plate clean and bright. The operation will also prevent the formation of rust.

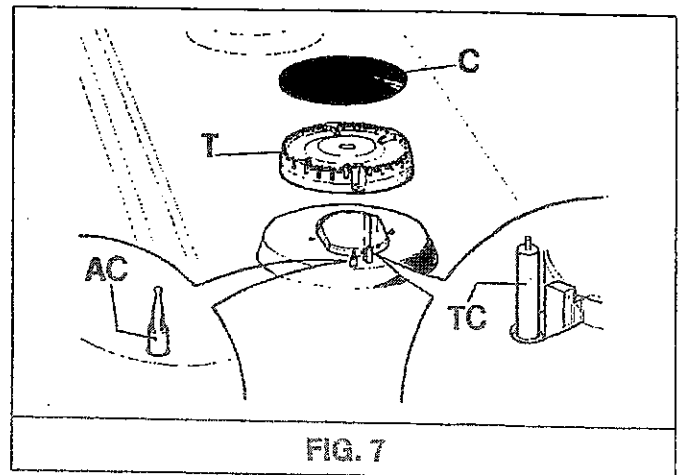
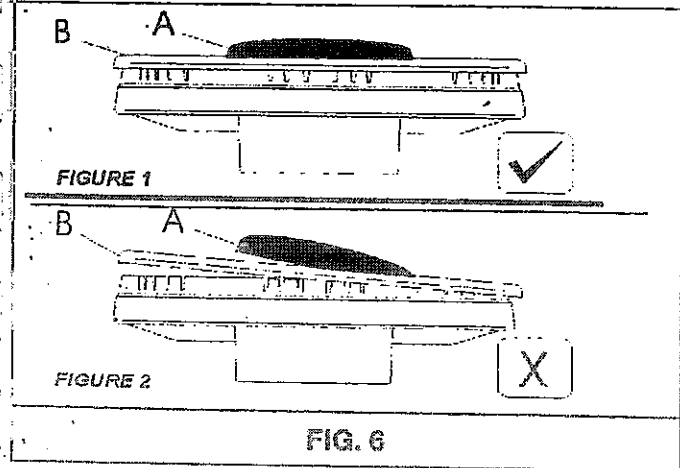

# INSTALLATION

## TECHNICAL INFORMATION FOR THE INSTALLER

*This appliance shall be installed only by authorised personnel and in accordance with the manufacturer's installation instructions, local gas fitting regulations, municipal building codes, water supply regulations, electrical wiring regulations, AS 5601/AG 601 – Gas Installations and any other statutory regulations.*

### 3) INSTALLING THE HOT PLATE

Check that the appliance is in a good condition after having removed the outer packaging and internal wrappings from around the various loose parts. If in any doubt, do not use the appliance and contact a qualified technician.

**Never leave the packaging materials (cardboard, bags, polystyrene foam, staples, etc.) within children's reach since they could become potential sources of danger.**

The measurements of the opening made in the top of the modular cabinet and into which the hot plate will be installed are indicated in either fig.8. Always comply with the measurements given for the hole into which the appliance will be recessed (see fig. 9).

*The appliance belongs to class 3 and is therefore subject to all the provisions established by the provisions governing such appliances.*

### 4) FIXING THE COOKTOP

The hot plate has a special seal which prevents liquid from getting into the cabinet. Strictly comply with the following instructions in order to correctly apply this seal:

- Detach the seals from their backing, checking that the transparent protection still adheres to the seal itself.
- Overturn the hot plate and correctly position seal "E" (fig. 10) under the edge of the hot plate itself, so that the outer side of the seal perfectly matches the outer edge of the hot plate. The ends of the strips must fit together without overlapping.
- Evenly and securely fix the seal to the hot plate, pressing into place with the fingers and remove the strip of protective paper from the seal and set the plate into the hole made in the cabinet.
- The prospective walls (left or right) that exceed the working table in height must be at a minimum distance from the cutting as mentioned both in the columns and the scheme.
- In order to avoid accidentally touching the potentially hot base of the cooktop, it is necessary to fix a wooden insert panel 60 mm minimum from the top of the bench. Fix the 25 mm spacers supplied to the bottom panel of the cooktop to ensure a 25 mm gap between the cooktop base and the wooden insert panel (fig. 8).

### COMPLY WITH THE DIMENSIONS

	A	B	C	D	E
4F	553	473	65	62	65

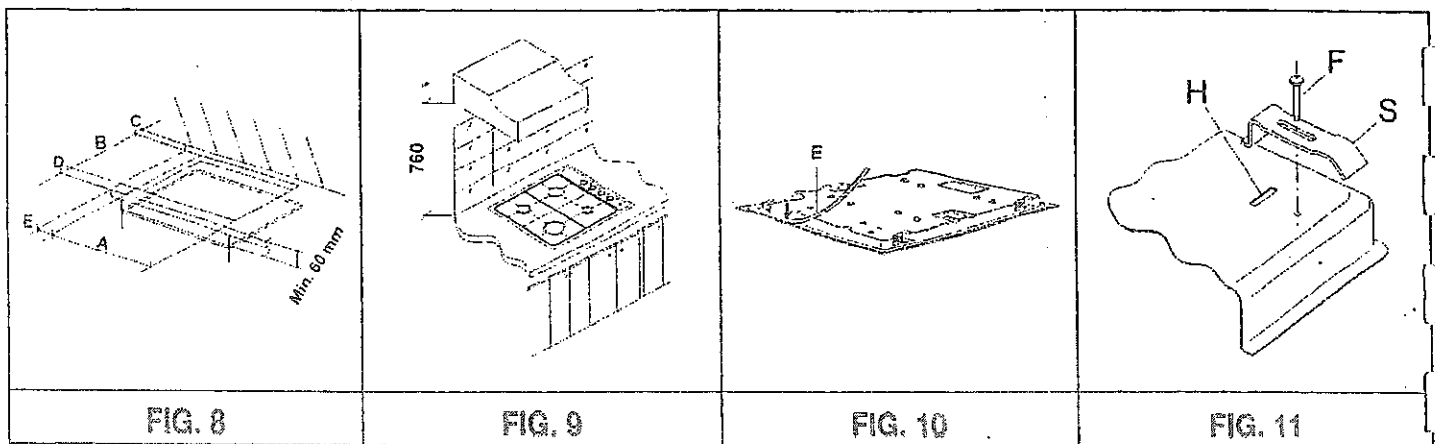

# INSTALLATION

## 5) LOCATION AND VENTILATION

Ventilation must be in accordance with AS5601/AG 601 – Gas Installations.

In general, the appliance should have adequate ventilation for complete combustion of gas, proper flueing and to maintain temperature of immediate surroundings within safe limits.

## 6) GAS CONNECTION

The gas connection is located in the rear and on the underside of the appliance 100 mm from the right hand side.

### Natural Gas

Both Natural and Town Gas installations require the connection of a gas regulator at the appliance. This regulator is supplied with the appliance on purchase.

Assemble the regulator (noting the gas flow direction) and transition pieces (supplied with the appliance), in accordance with figure 12.

The transition piece on the supply side of the regulator must be provided by the installer.

### Liquified Petroleum Gas

In a LPG installation the gas regulation is made at the gas cylinder and regulation at the appliance is not required. To connect supply to the appliance use transition pieces as shown in figure 13. These pieces are supplied with the appliance on purchase.

### WARNING:

**THE BURNER FLAME MUST BE ADJUSTED BY THE INSTALLER.**

**FAULTY INSTALLATION WILL NOT BE COVERED UNDER WARRANTY.**

## 7) ELECTRICAL CONNECTION

The appliance is supplied with a 1800 mm long flexible supply lead.

The point of attachment for this lead is located at the rear and on the underside of the appliance 380 mm from the right hand side.

The voltage and power consumption are detailed on the underside of the appliance. Ensure that the appliance is correctly rated to the supply.

Connect appliance by way of a switched power point.

### THE APPLIANCE MUST BE EARTHED

Ensure that this power point is properly earthed. Look at the connection wiring diagrams (fig. 14 - 15).

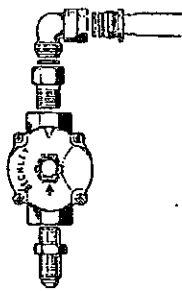

FIG. 12

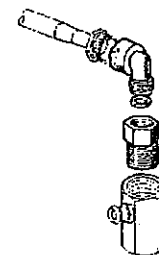

FIG. 13

### HOTPLATES WITH 5 BURNERS

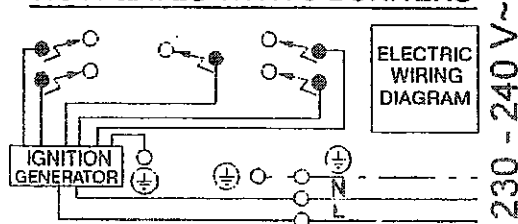

FIG. 14

### HOTPLATES WITH 4 BURNERS

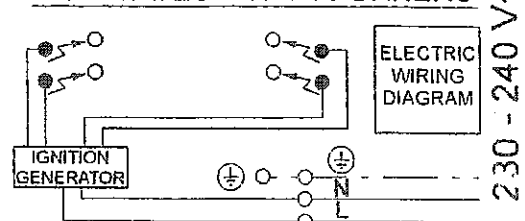

FIG. 15

# ADJUSTMENTS

**Always disconnect the appliance from the electricity main before making any adjustments. All seals must be replaced by the technician at the end of any adjustments or regulations. Our burners do not require primary air adjustment.**

## **a) Data Label**

The Data Label is located on the underside of the hotplate. A duplicate Data Label is supplied to adhere in an accessible area next to the hotplate. This hotplate is suitable for Natural Gas and Universal LPG; ensure that the available gas supply matches the Data Label.

## **b) Before Leaving**

Check that there are no gas leaks, but do not use a naked flame to detect gas leaks. Ignite all burners to ensure correct operation of gas valves, burners, ignition and if fitted, flame failure valves. Turn gas taps to low flame position and observe stability of the flame. When satisfied with the hotplate, please instruct the user on the correct method of operation. In case the appliance falls to operate correctly after all checks have been carried out, refer to the authorised service provider in your area.

## **8) TAPS**

Our taps are suitable for all the gas, they are male conical type at one way.

### **"Reduced rate" adjustment**

- Switch on the burner and turn the relative knob to the "Reduced rate" position (small flame fig. 1).
- Remove knob "M" (fig. 16) of the tap, which is simply pressed on to its rod.
- Insert a small screwdriver "D" into hole "C" (fig. 16) and turn the throttle screw to the right or left until the burner flame has been adequately regulated to the "Reduced rate" position.

Check that the flame does not go out when the knob is sharply switched from the "Full on" to the "Reduced rate" position.

***It is understood that only burners operating with Natural gas should be subjected to the above mentioned adjustments. The screw must be fully locked when the burners operate with Liquid gas.***

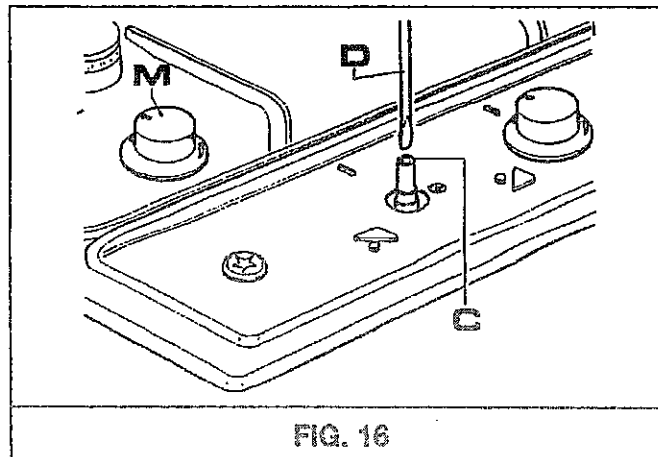

FIG. 16

# CONVERSIONS

## 9) U-LPG TO NATURAL GAS CONVERSION PROCEDURE

Appliance models: Gas stainless steel hotplate models:

**BCG640** 4 Burners  
**BCG641** 4 Burners

1. Remove each burner cap and burner skirt.
2. Remove the U-LPG main injector with a 7 mm/VF tube spanner and replace with the appropriate size Natural Gas injector for each burner. The following injector sizes are required for Natural Gas:

<i>Burner</i>	<i>Main injector</i>
Wok	1.76 mm
Rapid	1.55 mm
Semirapid	1.20 mm
Auxiliary	0.90 mm

3. Shut off gas supply to the appliance.
4. Disconnect gas inlet pipe from the U-LPG Gas test point inlet fitting.
5. Remove the U-LPG test point inlet fitting from the appliance.
6. Fit the Natural Gas Regulator supplied in the conversion kit.
7. Connect the gas supply to the Regulator.
8. Check for gas leaks. Do not use a naked flame to check for gas leaks.
9. Adjust the gas pressure to 1.00 kPa.
10. Remove the control knob, with a thin shaft blade screwdriver down the centre of each gas valve shaft, screw the by-pass injector anti-clockwise. Test the appliance on both high and low flame for each burner. If the burner fails to remain alight or the flame is not stable on the simmer setting, adjust the by-pass screw, until flame is stable.
11. If not already removed, remove the "Only for use with U-LPG" label adhered to the bottom panel near the gas connection.

## 10) NATURAL GAS TO UNIVERSAL LPG CONVERSION PROCEDURE

Appliance models: Gas stainless steel hotplate models:

**BCG640** 4 Burners  
**BCG641** 4 Burners

1. Remove each burner cap and burner skirt.
2. Remove the Natural Gas main injector with a 7 mm/VF tube spanner and replace with the appropriate size U-LPG main injector for each burner. The following injector sizes are required for U-LPG:

<i>Burner</i>	<i>Main injector</i>
Wok	1.06 mm
Rapid	0.94 mm
Semirapid	0.73 mm
Auxiliary	0.54 mm

3. Remove the control knob, with a thin shaft blade screwdriver down the centre of each gas valve shaft, screw the by-pass injector fully clockwise.
4. Shut off gas supply to the appliance.
5. Disconnect gas inlet pipe from the Natural Gas Regulator.
6. Remove the Natural Gas Regulator from the appliance.
7. Fit the U-LPG test point inlet fitting supplied in the conversion kit.
8. Connect the gas supply to the inlet fitting.
9. Check for gas leaks. Do not use a naked flame to check for gas leaks.
10. Adjust the gas pressure to 2.75 kPa.
11. Test the appliance on both high and low flame for each burner and check the gas pressure. If the burner fails to remain alight or the flame is not stable on the simmer setting, adjust the by-pass screw, until flame is stable.
12. If not already removed, remove the "Only for use with Natural Gas" label adhered to the bottom panel near the gas connection.

# CONVERSIONS

## 11) REPLACING THE INJECTORS

The burners can be adapted to different types of gas by installing injectors suited to the type of gas required. To do this, first remove the burner tops using a wrench "B". Now unscrew injector "A" (see fig. 17) and fit a injector corresponding to the type of gas required.

It is advisable to tighten the injector in place.

**After the injectors have been replaced, the burners must be regulated as explained in paragraphs 8. The technician must reset any seals on the regulating or pre-regulating devices and**

**affix the label corresponding to the new gas regulation on the appliance instead of the already existing one. This label is supplied in the packet containing the spare injectors.**

**The envelope with the injectors and the labels can be included in the kit, or at disposal to the authorized customer Service Centre.**

For the sake of convenience, the nominal rate chart also lists the heat inputs of the burners, the diameter of the injectors and the working pressures of the various types of gas.

## BURNER ARRANGEMENT ON THE HOT PLATE

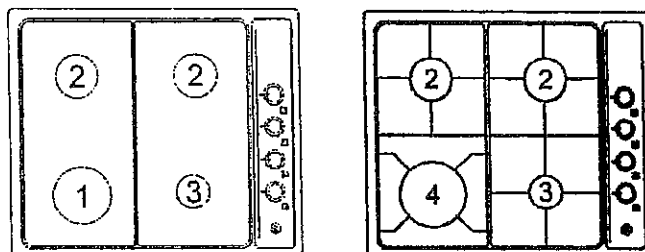

TABLE

BURNERS		GAS	NORMAL PRESSURE (kPa)	INJECTOR DIAMETER (1/100mm)	NOMINAL HEAT INPUT (MJ/h) MAX.
N°	DESCRIPTION				
1	RAPID	U-LPG	2.75	94	12.0
		NATURAL	1.00	155	12.0
2	SEMI-RAPID	U-LPG	2.75	73	6.9
		NATURAL	1.00	120	7.3
3	AUXILIARY	U-LPG	2.75	54	3.8
		NATURAL	1.00	90	4.2
4	ULTRA RAPID	U-LPG	2.75	106	15.0
		NATURAL	1.00	176	15.0

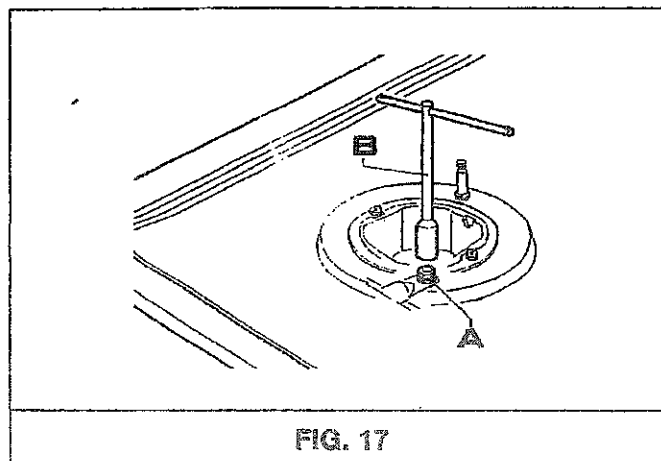

FIG. 17

# SERVICING

**Always turn off the electrical ignition before proceeding with any servicing operation.**

**Servicing should be carried out only by authorised personnel.**

## 12) REPLACING HOT PLATE PARTS

To replace the components fit inside the hob, take off the knobs, all the movable parts of the hobs (trivets, burners and caps) and the screws "V" on the burners (see fig. 18).

After having carried out the above listed operations, the replacement of the electrical components and the taps is possible.

**REMARKS:** before replace the taps on the hob without flame failure device, take off the microswitches fit on the taps.

It is advisable to change seal "D" whenever a tap is replaced to ensure a perfect tightness.

## Greasing the taps (see fig. 19 - 20)

If a tap becomes stiff to operate, it must be immediately greased in compliance with the following instructions:

- Remove the tap.
- Clean the cone and its housing using a cloth soaked in solvent.
- Lightly spread the cone with the relevant grease.
- Fit the cone back in place, operate it several times and then remove it again. Eliminate any excess grease and check that the gas ducts have not become clogged.
- Fit all parts back in place, complying with the demounting order in reverse.
- The tight closure test must be done using a foamy liquid.

To facilitate the servicing technician's task, here is a chart with the types and sections of the powering cables and the ratings of the electrical components.

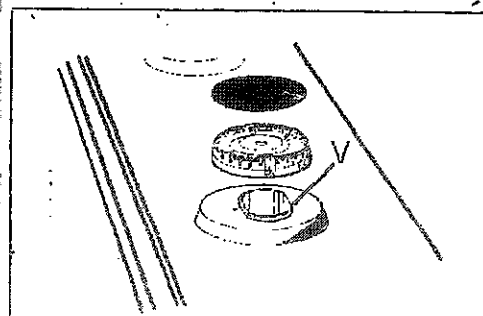

FIG. 18

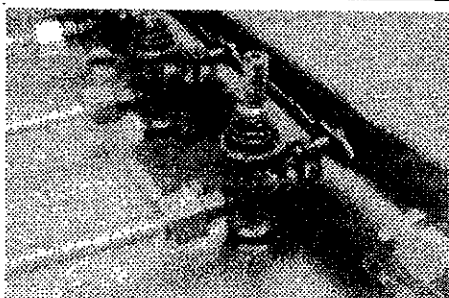

FIG. 19

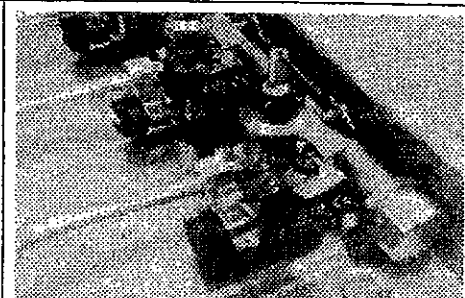

FIG. 20

# TECHNICAL ASSISTANCE AND SPARE PARTS

## MEA - BLANCO

### TECHNICAL ASSISTANCE AND SPARE PARTS

#### **NEW SOUTH WALES**

*Head Office, Sales & Marketing Office*  
104 Vanessa Street  
Kingsgrove NSW 2208  
Telephone: 02 9503 2888  
Facsimile: 02 9503 2810

#### **Service and Spare Parts**

*All General Whitegoods Service*  
Telephone: 02 9756 1511  
Facsimile: 02 9756 1091

#### **AUSTRALIAN CAPITOL TERRITORY**

#### **Service and Spare Parts**

*Premier Appliance*  
Telephone: 02 6280 5087  
Facsimile: 02 6280 6783

#### **VICTORIA**

*State Office and Showroom\**  
35 Centre Road  
Scoresby VIC 3179  
Telephone: 03 8756 7813  
Facsimile: 03 8756 7907

#### **Service and Spare Parts**

*Advantage Appliances*  
Telephone: 03 9543 2088  
Facsimile: 03 9544 2102

#### **QUEENSLAND**

*State Office and Showroom\**  
Ground Floor, Building 1  
Bowengate Business Park  
Cnr Bowen Bridge Road & Campbell Street  
Bowen Hills QLD 4066  
Telephone: 07 3216 1644  
Facsimile: 07 9254 1578

#### **Service and Spare Parts**

*Tri-Us Appliances*  
Telephone: 07 3290 4833  
Facsimile: 07 3290 2911

#### **Endeavour Appliances**

Telephone: 07 3852 2477  
Facsimile: 07 3852 2465

#### **SOUTH AUSTRALIA**

#### **Service and Spare Parts**

*Prestige Appliance Repair Centre*  
Telephone: 08 8352 2022  
Facsimile: 08 8353 3044

#### **WESTERN AUSTRALIA**

*Agent and Showroom*  
TCB Sales and Marketing  
5 Sangiorgio Court  
Osborne Park WA 6196  
Telephone: 08 9201 7850  
Facsimile: 08 9201 7855

#### **Service and Spare Parts**

*Phipps Electrical Services*  
Telephone: 08 9470 1175  
Facsimile: 08 9361 6335

#### **TASMANIA**

*Agent and Sales Office*  
Mark Pearce Agencies  
23 Tranmere Road  
Howrah TAS 7018  
Tel/Fax: 03 6247 9215

#### **Service and Spare Parts**

*Northern Electrical Services*  
Telephone: 03 6331 3971  
Facsimile: 03 6331 3992

#### **Baldocks Appliance Service**

Telephone: 03 6234 5995  
Facsimile: 03 6234 8134

#### **NORTHERN TERRITORY**

*Agent and Sales Office*  
Atkins Agencies  
PO Box 39802  
Winnellie NT 0820  
Telephone: 08 8932 9475  
Facsimile: 08 8932 9476

\* Showrooms open 6 days a week